

- Highly productive machine
- High dynamic and thermal stability
- High accuracy at machining
- Linear guideways in all axes
- Direct measuring in all axes
- Easy loading of big workpieces
- Completely covered work zone
- Favourable ratio machine area/ workpiece size
- Machining in 3 – 5 axes
- Utilization of HSC technology
- Very ecological operation
- Ergonomical solution of machine
- Ecologically friendly

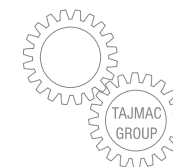

STANDARD EQUIPMENT

- SIEMENS digital drives
- HEIDENHAIN direct linear measuring
- Spindle thermal stabilization
- Tool holder automatic air blasting
- Tool outer cooling
- Completely covered work zone
- Chip conveyor with integrated coolant tank
- Working cycle end signalling
- Rack-type tool magazine with capacity of 40 tools

OPTIONAL EQUIPMENT*

- Cooling through spindle axis
- Cooling with minimum quantity of lubricant
- Tool measuring probe
- Workpiece measuring probe
- CNC two-axis head
- Two-axis rotary table
- Remote diagnostics

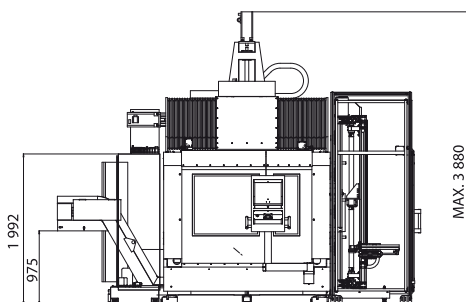
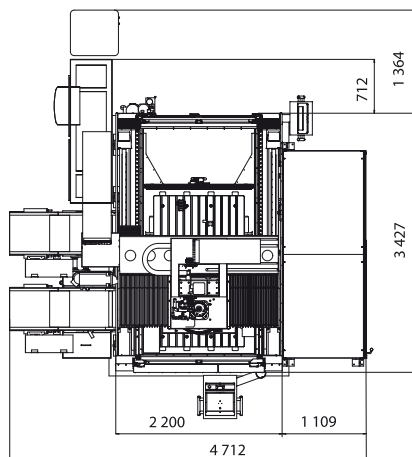

Working travel

X-axis – cross slide	1 000 mm
Y-axis – cross rail	1 800 mm
Z-axis – ram	600 mm

Working area

Dimension of tables	1 200 × 2 000 mm
Number of T-slots in table	11
Dimension of slots – 2nd T-slot from the right	18H7 mm
– the other T-slots	18H8 mm
Pitch of T-slots	100 mm

Maximum load	3 000 + 3 000 kg
--------------	------------------

Distances	Electrospindle	CNC two-axis head
Spindle nose to table	150 – 750 mm	100 – 700 mm

Feeds in X, Y, Z axes

Max. working feed	20 m/min
Rapid traverse	40 m/min
Maximum acceleration of axes	5 m/sec ²

Spindle unit

Type	electrospindle			
Max. spindle speed	15 000 rpm	18 000 rpm*	18 000 rpm*	14 000 rpm*
Max. spindle power output	31 kW	32 kW	31 kW	37 kW
Max. spindle torque	197 Nm	90 Nm	197 Nm	236 Nm
Clamping taper	ISO 40	HSK-A63	HSK-A63	HSK-A100

Accuracy

Measuring system in X, Y, Z axes	direct
Positioning accuracy – VDI/DGQ 3441 in X, Y, Z axes	0.008 mm
Repeatability – VDI/DGQ 3441 in X, Y, Z axes	0.005 mm

Automatic tool changer

Number of tool pots in ATC	40 up to 130
Tool interchange time (tool - tool)	8 sec
Tool maximum diameter	
– at fully occupied adjacent tool pots in ATC	110 mm
– at adjacent tool pots in ATC not occupied	160 mm
Tool maximum length	
– machine with electrospindle	380 mm
– machine with CNC two-axis head	240 mm
Tool including holder maximum weight	15 kg

Pneumatic unit

Air pressure at inlet	0.6 – 0.8 MPa
Operational pressure	0.55 MPa

Electric power requirements

Connecting voltage	3 × 400 V/50 Hz	3 × 480 V/60 Hz
Operational power input	45 kVA	
Current at fully loading of machine	125 A	

Weights

Machine (including tool changer)	14 500 kg
----------------------------------	-----------

Control system HEIDENHAIN, SINUMERIK*, FANUC*

CNC TWO-AXIS HEAD – Spindle*

Nominal power output	23 kW
Nominal torque	72 Nm
Maximum speed	19 000 rpm
Clamping taper	HSK-A63

A-axis

A-axis range	±115 °
A-axis speed of rotation	max. 60 rpm
Maximum torque	538 Nm
Torque at locking	2 500 Nm

C-axis

C-axis range	±200 °
C-axis speed of rotation	max. 60 rpm
Maximum torque	500 Nm
Torque at locking	2 000 Nm

Accuracy (VDI/DGQ 3441)

Positioning accuracy (P) – A-axis (without electronic compenzation)	±20 arc. sec
Positioning accuracy (P) – C-axis (without electronic compenzation)	±10 arc. sec

TWO-AXIS ROTARY TABLE*

A-axis (tilting axis)

A-axis range	±95 °
A-axis speed of rotation	max. 25 min ⁻¹
Maximum torque (T. M. max)	960 Nm
Maximum weight of workpiece for continuous interpolation	500 kg

C-axis (rotary axis)

	Turning**	Milling
Table clamping area (diameter)	∅ 600* / ∅ 800 mm	∅ 600* / ∅ 800 mm
C-axis range	360 °	360 °
Speed of rotation	max. 400 rpm	max. 100 rpm
Maximum torque (T. M. max)	653 / 1 000 Nm	628 / 1 000 Nm
Braking torque	3 000 Nm	3 000 Nm

Accuracy (VDI/DGQ 3441)

Positioning accuracy (P) – A-axis	12 arc. sec
Positioning accuracy (P) – C-axis	6 arc. sec

** in combination with electrospindle having HSK-A63 or HSK-A100 tool configuration

Descriptions of illustrations and specifications may not always correspond with the machine latest version.

Manufacturer TAJMAC-ZPS, a. s. Tržida 3. května 1180 764 87 Zlín, Malenovice CZECH REPUBLIC Tel: +420 577 532 072 Fax: +420 577 533 626 www.tajmac-zps.cz e-mail: info@tajmac-zps.cz	Holding TAJMAC-MTM, S. p. A. Via Gran Sasso 15 20092 Cinisello Balsamo (Mi) ITALY Tel: + 39 02 66017878 Fax: + 39 02 66011457 www.tajmac-mtm.it e-mail: tajmac@tajmac-mtm.it
---	---