

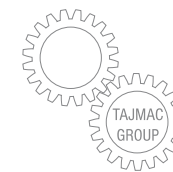

- Complex machining
- Utmost flexibility
- High dynamics and cutting power
- High rigidity and damping property
- High performance
- Long-lasting high accuracy
- Guards making manipulation with workpieces easy
- Ecologically friendly

TURNMILL 1250

TECHNICAL DATA



TURNMILL 1250 represents the original solution of new generation of multi-professional machining centre.

Upper gantry-type turning and milling machining centre in the basic execution is provided with four controlled axes:

X-axis – cross rail longitudinal travel

Y-axis – slide cross travel

Z-axis – ram vertical travel

C-axis – clamping plate rotary axis

Rotary milling head with tilting movement in the B-axis is increasing the number of controlled axes to 5.

TECHNOLOGICAL CAPACITY

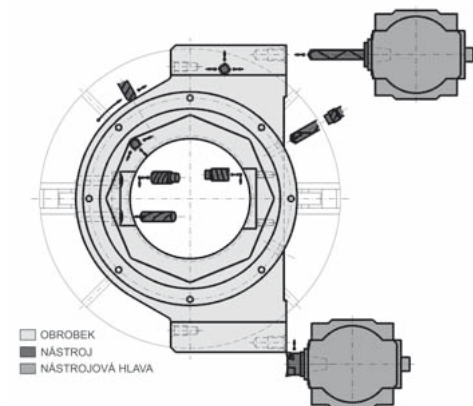
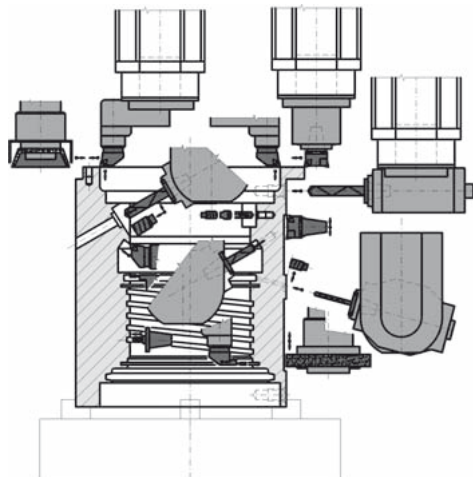

OBROBEK
 NÁSTROJ
 NÁSTROJOVÁ HLAVA

STANDARD VERSION

- SINUMERIK control system
- Digital drives
- Clamping plate with 16 T-slots 12×28 mm
- Direct measuring in X, Y, Z axes
- Direct measuring in C-axis
- Built-in spindlemotor 6 500 rpm
- ISO 50 clamping taper for rotary tools
- Capto C8 clamping system for turning tools
- Magazine for 45 tools and 10 tool heads
- Automatic blasting with air of clamping boundary and tool heads hollows
- Outer tool cooling – pressure of 70 bars
- Through tool axis coolant of 70 bars for all rotary heads
- Preparation for application of coolant ultra-high pressure of 350 bars
- System of work zone washing-off and tool blasting with air
- Coolant filtration unit
- Steelbelt chip conveyor
- 2 worm-type chip conveyors

OPTIONAL EQUIPMENT

- Equipment of machine with tool heads
- Three-jaw or four-jaw self-centring chuck
- Active checking of tool at machining
- Checking of workpiece dimensions
- Monitoring of cutting process
- Other clamping system of tools
- Drive of live tools – 8 000 rpm or 12 000 rpm
- High-pressure cooling device – 350 bars
- Dressing device of grinding wheels
- Tool magazine with higher number of tool pockets
- Rotary observational window
- Air exhausting system
- Electrical equipment for other voltage and frequency
- Auxiliary control panel
- Transformation of coordinates
- Other CNC control system
- Remote diagnostics
- Other clamping plate and workpiece clamping system
- Automatic system of pallet exchange
- Automatic clamping fixtures pro workpiece location outside the machine
- Platform for machine operator

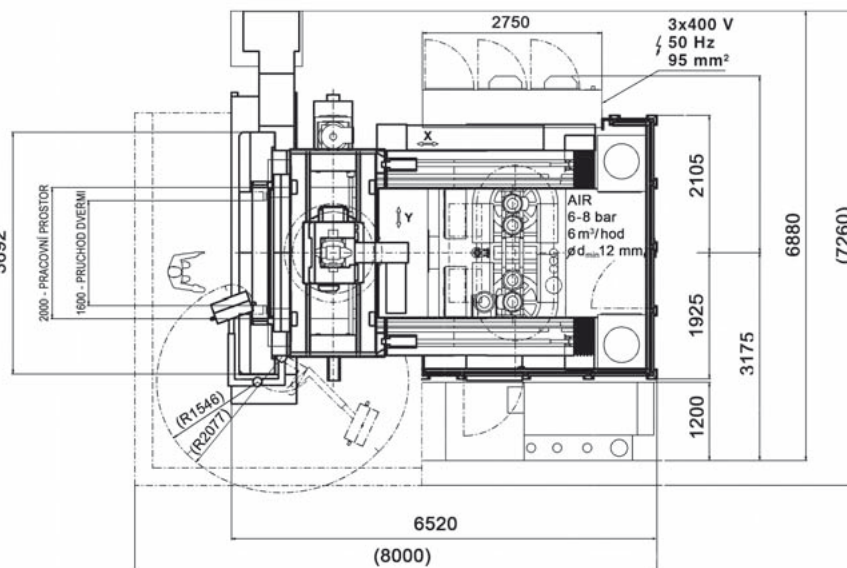

Working capacity

Max. swing diameter	1 950 mm
Max. turning diameter	1 500 mm
Min. internal diameter of turning	140 mm
Max. height of workpiece	1 250 mm

Travels

X-axis – cross rail	1 400 mm
Y-axis – slide	1 500 mm
Z-axis – ram	1 250 mm
C-axis – clamping plate; increment	0.001 °
Max. working feed	20 m/min
Rapid traverse	30 m/min
Acceleration	5 m /sec ²

Accuracy (VDI/DGQ 3441)

Positioning accuracy (P)	0.012 mm
Repeatability (Ps max.)	0.008 mm
C-axis positioning accuracy	12 arc sec

Clamping plate

Plate diameter	1 250 mm
Max. load	6 000 kg
Max. speed	630 rpm
Main motor power output S1 / S6 – 40 %	60/84 kW
Torque S1 / S6 – 40 %	14 600/19 490 Nm
C-axis of clamping plate – speed/torque	6 rpm/10 000 Nm

Drive of rotary tools

Max. speed	6 500 rpm
Power output S1 / S6 – 40 %	38/48 kW
Torque S1 / S6 – 40 %	300/384 Nm

System of tool automatic exchange

Max. number of tool heads	10
Clamping taper of rotary/turning tool	ISO 50 / Capto C8
Tool magazine capacity	45 tools
Max. dia of tool (adjacent pockets empty)	250 mm
Max. length of tool	350 mm
Max. weight of tool	15 kg

Power supplies

Nominal voltage of mains	3 × 400 V / 50 Hz
Power input	100 kVA
Compressed air	0.6 – 0.8 MPa

Complementary data

Machine max. working height	5 400 mm
Machine weight (standard version)	40 000 kg

Descriptions of illustrations and specifications may not always correspond with the machine latest version.

Manufacturer
TAJMAC-ZPS, a. s.
 Třída 3, května 1180
 764 87 Zlín, Malenovice
 CZECH REPUBLIC
 Tel.: +420 577 532 072
 Fax: +420 577 533 626
 www.tajmac-zps.cz
 e-mail: info@tajmac-zps.cz

Holding
TAJMAC-MTM, S. p. a.
 Via Gran Sasso 15
 20092 Cinisello Balsamo (Mi)
 ITALY
 Tel.: + 39 02 66017878
 Fax: + 39 02 66011457
 www.tajmac-mtm.it
 e-mail: tajmac@tajmac-mtm.it

TIGRIS, s.r.o., Zlín 3/2013